

كرز و ليمون

Karaz w
Laimoon

The **Videos** of
Previous Presentations
are also on . . .

www.karazwlamoon.com

A Quick List of the
Zoom events
since **April 2020**

Wednesday
29 April 2020

The Ultimate
Thinking Machine:
the Human Brain
Dr. Georges Haddad



Beethoven Faces the Abyss: The 5th Symphony



Akram Najjar
22 April 2020

Wednesday
6 May 2020

Lebanese
Maritime Heritage
Eddy Choueiry



Wednesday
13 May 2020

الأربعاء 13 أيار
الساعة 8:15

فن الحكواتي

سارة قصير: حكايتية وباحثة في فن الحكواتي



20 May 2020

Gershwin's Rhapsody in Blue

Why is it Blue?
and why is it a Rhapsody?

Akram Najjar





27 May 2020

Why are Pianists quiet about their Profession?

Waleed Howrani

17 June 2020

Read Aloud 6

(Your own writing)



24 June 2020

WE LOVE SHORT FILMS

7 Unusual Short Films

1 July 2020

الأربعاء 1 تموز 2020

الأحوال الشخصية من منظور الحريات الفردية

The personal status laws through
the prism of individual freedoms

مقالمفكرة القانونية

8 July 2020 8 تموز 2020

أوهام تشريع الحشيشة في لبنان
(كريم نمور – المفكرة القانونية)

The Illusions of the
Legalization of Cannabis
(Karim Nammour)



15 July 2020



Are there Illusions in Music?
Jad Azkoul

29 July 2020



Shakuhachi

The Japanese Flute

Kyle Kamal Helou

Beethoven and Asymmetry

Violin Concerto (1st Movement)



Akram Najjar
16 December 2020

3 June 2020



**The Lure of
the Masbaha**

**Najib
Takieddine**



From Journalism to Art (A Healing Journey)

(Espace Fann / Kinship Stories)

6 January 2021



Yasmine Dabbous



Hicham Bou Nassif
13 January 2021

String Together . . . Introducing . . . the United Strings of Europe Julian Azkoul and Ariel Lang

Music Club
Thursday
21 Jan 2021



Beirut Built Heritage Rescue 2020

Grace Rihan Hanna



25 Jan 2021

How did **Bob Dylan** Revolutionize Song Writing?

Akram Najjar
1 Feb 2020



The Guitar as Orchestra? The Revolutionary Guitar Playing Method of Abel Carlevaro

Jad Karim Azkoul

Music Club
8 Feb 2021



Concepts and Issues in and about Lebanon Art Stories

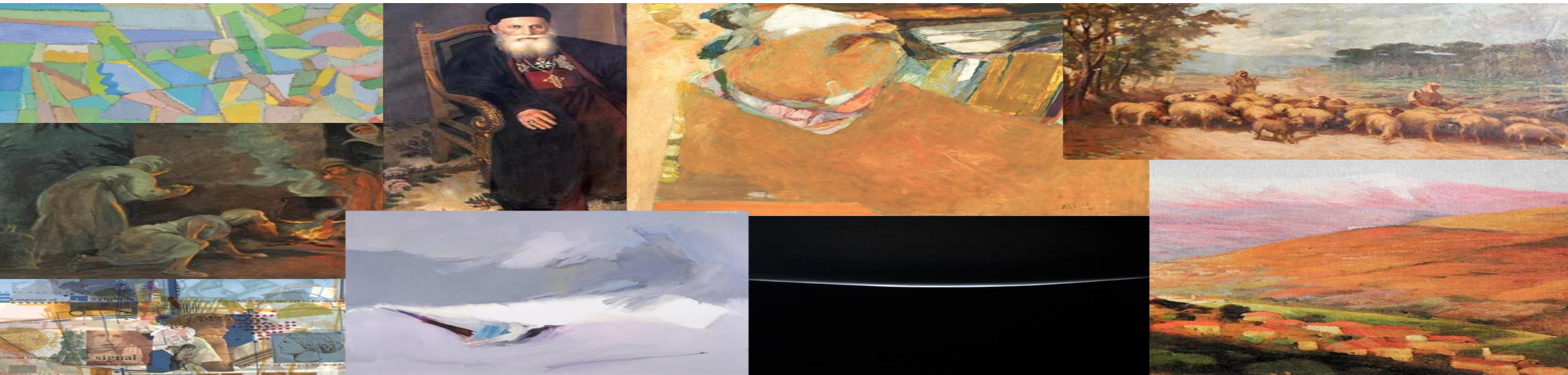

Zéna Meskaoui

15 Feb 2020

Picasso's Guernica: What's in a Painting?

Dr. Georges Haddad

(22 February)



Literature On Video

Come and Present your
Favorite Writer

Monday 1 March



Are we Reading Literature the Right Way?
And if not, How Else?

(Replaces: Literature on Video)



Literary Club

Akram Najjar

1 March 2020

AUB Archaeological Museum: Taking the Leap into the Digital Realm

Dr. Nadine Panayot Haroun (8 March)



Music Talk: Easter with Bach

Dr. Georges Haddad

22 March (Repeated on Thu 25 March 2020)



Music Talk: Easter with Bach

Dr. Georges Haddad

Thu 25 March (Repeat of 22 March)



The 1001 Secrets of Tea

Kamel Lawand
29 March 2020



Les Temples de l'Antiquité, la preuve par la pierre

François Farhat
5 April 2021

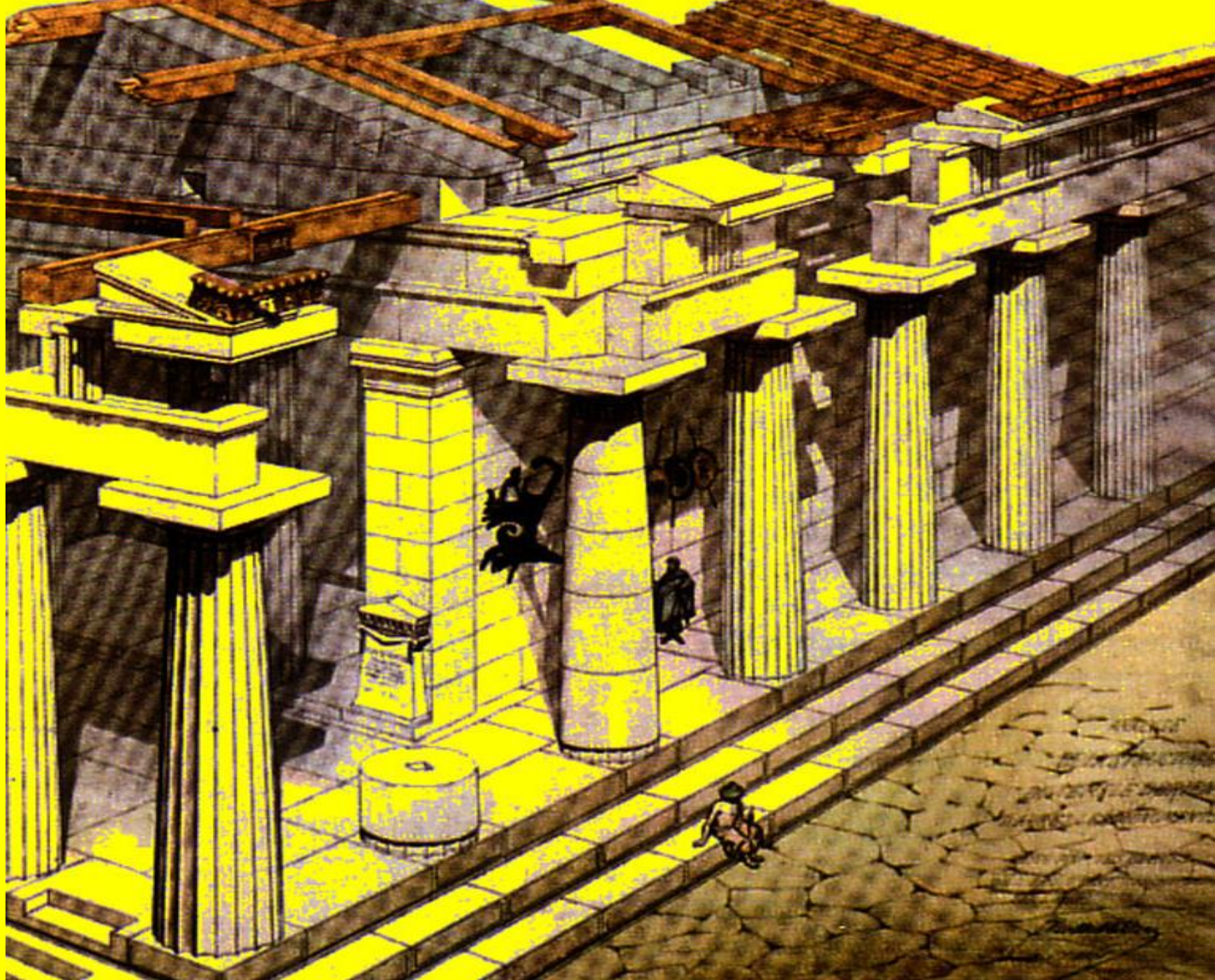



Music Talk:

The Battle of the Saxes

Akram Najjar - 12 April 2021

Music Talk:



Bach's Chaconne

Akram Najjar - 26 April 2021



Cryptocurrency: What's All the Fuss about? Michel Cruz - Monday 3 May 2021

Music Talk:

Liszt's
B minor Sonata

Akram Najjar - Monday 10 May 2021



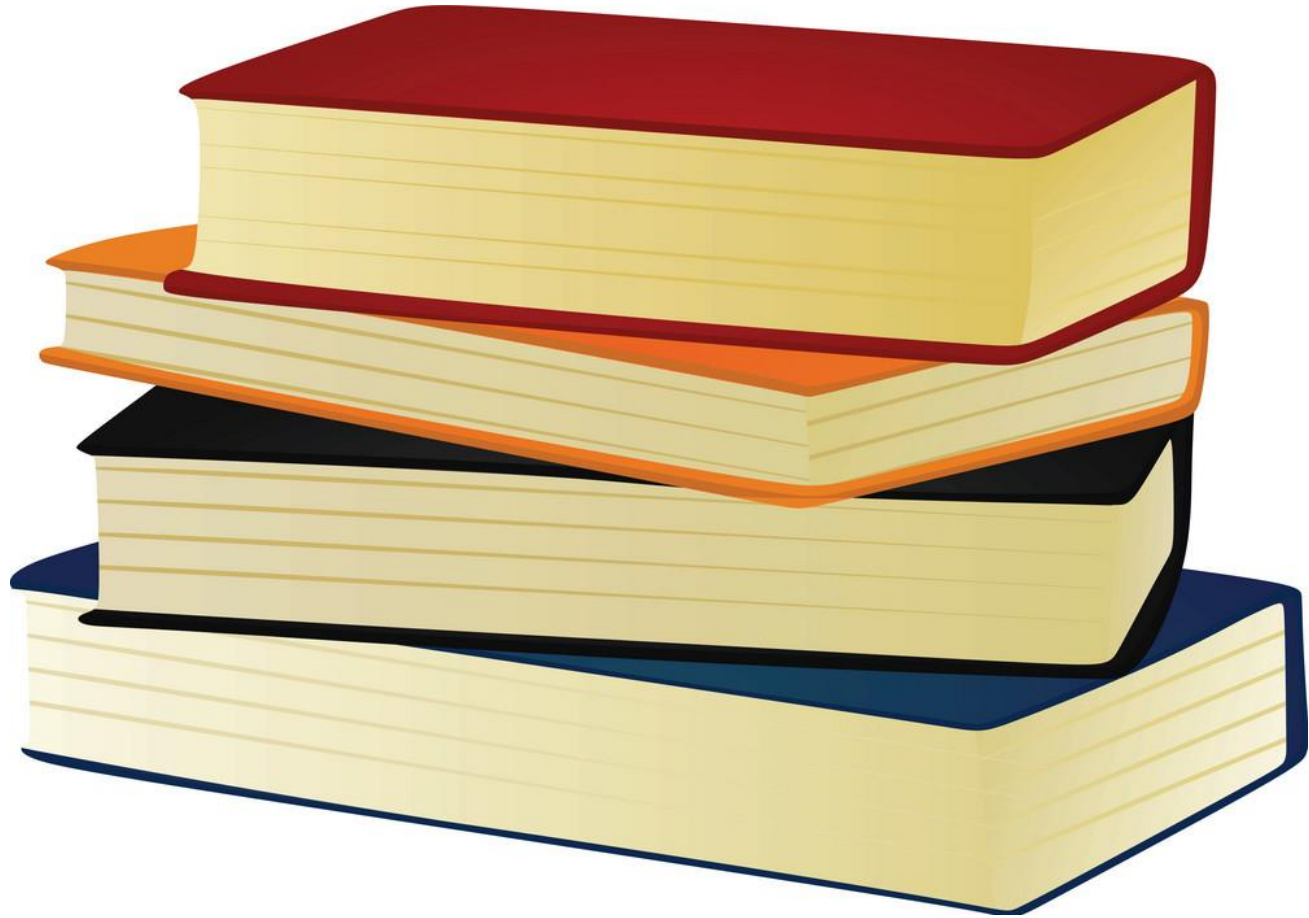

Literary Talk:

4 Book Reviews

Members of the
Lebanon Readers Society
Monday 17 May 2021

Art Talk:

Gian Lorenzo Bernini, le second Michel Ange

François Farhat

Monday 24 May 2021

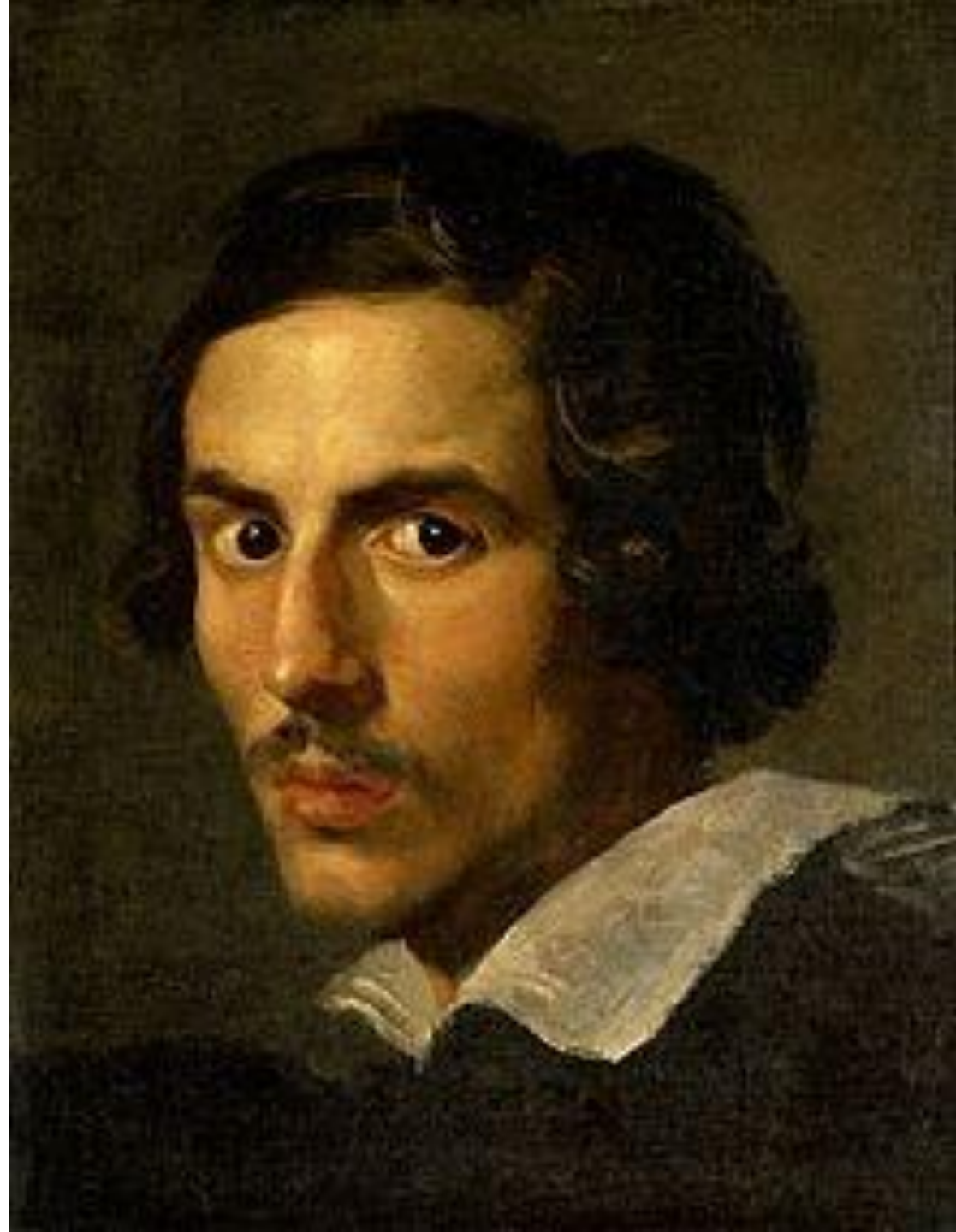

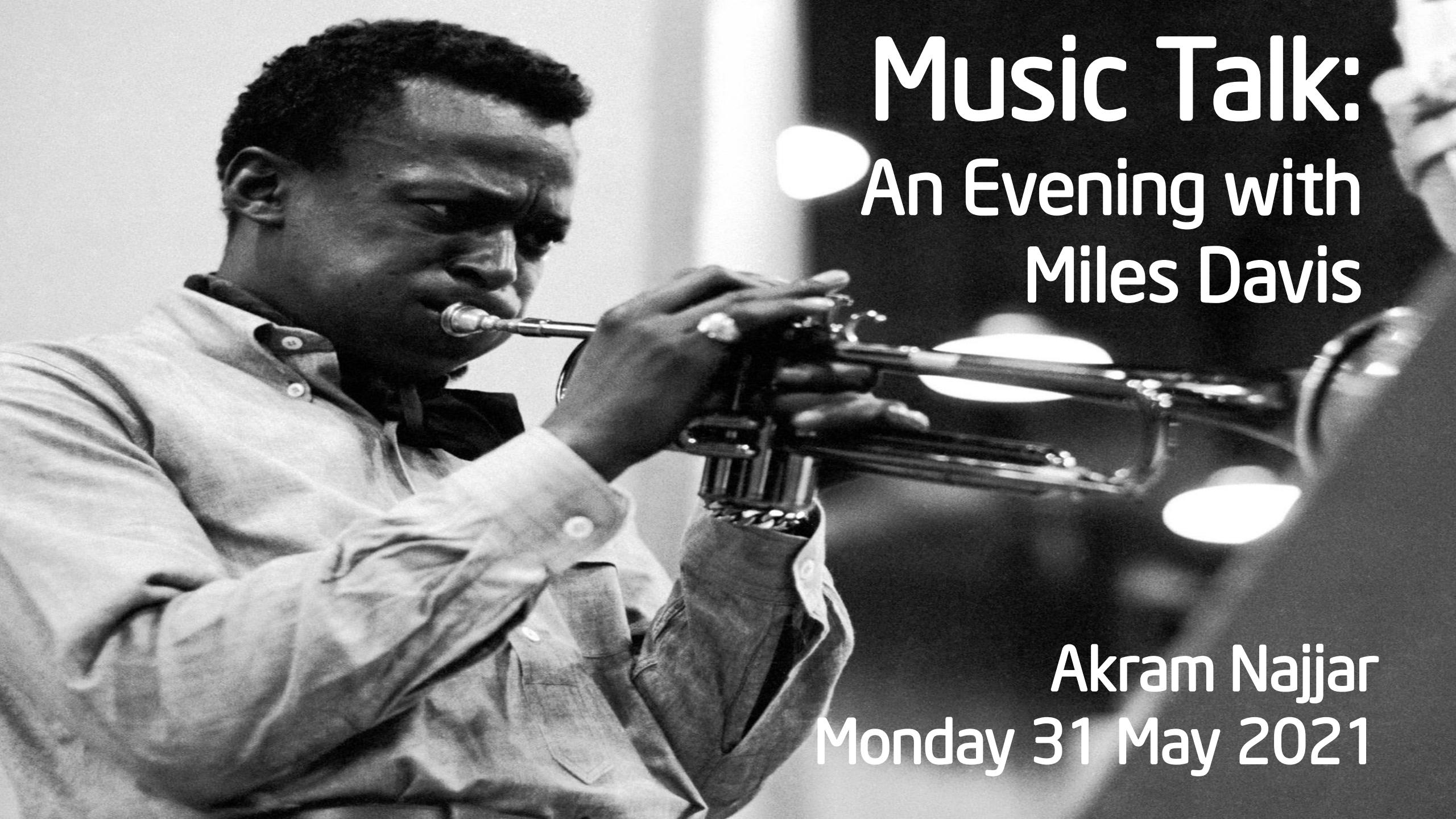

Music Talk: An Evening with Miles Davis

Akram Najjar
Monday 31 May 2021



Music Talk:
What (is) the Blues?

Akram Najjar
21 June 2021

A woman with dark hair, wearing a white sleeveless top, is leaning over a grand piano. She has her chin resting on her clasped hands and is looking towards the camera with a slight smile. The piano is a dark color with a light-colored keyboard. The background is dark, and the piano's lid is open, showing the internal strings and hammers.

Pianist Nada
28 June 2021

Music Talk:
The Importance of
Brahms' first Solo Piano Works

The Wonders of Coffee . . . Revealed

Kamel Lawand
5 July 2021



الدكتور الياس خليل

12 July 2021

Literary Talk:

تقدمة لتاريخ وأنواع واهمية

شعر الزجل في لبنان



The Art, Science
and Practice of
Ceramics and
Pottery.

Colette Naim
19 July 2021





Music Talk:

Akram Najjar
2 August 2021

Beethoven's Archduke Trio

الفدرالية:

هل تشكل جسر العبور الآمن نحو
الجمهورية الثالثة؟

ادغار قبوات

6 September 2021

L'Odyssée ? Rien n'est faux, mais . . .

François Farhat

13 September
2021



Music Talk: 20 September 2021

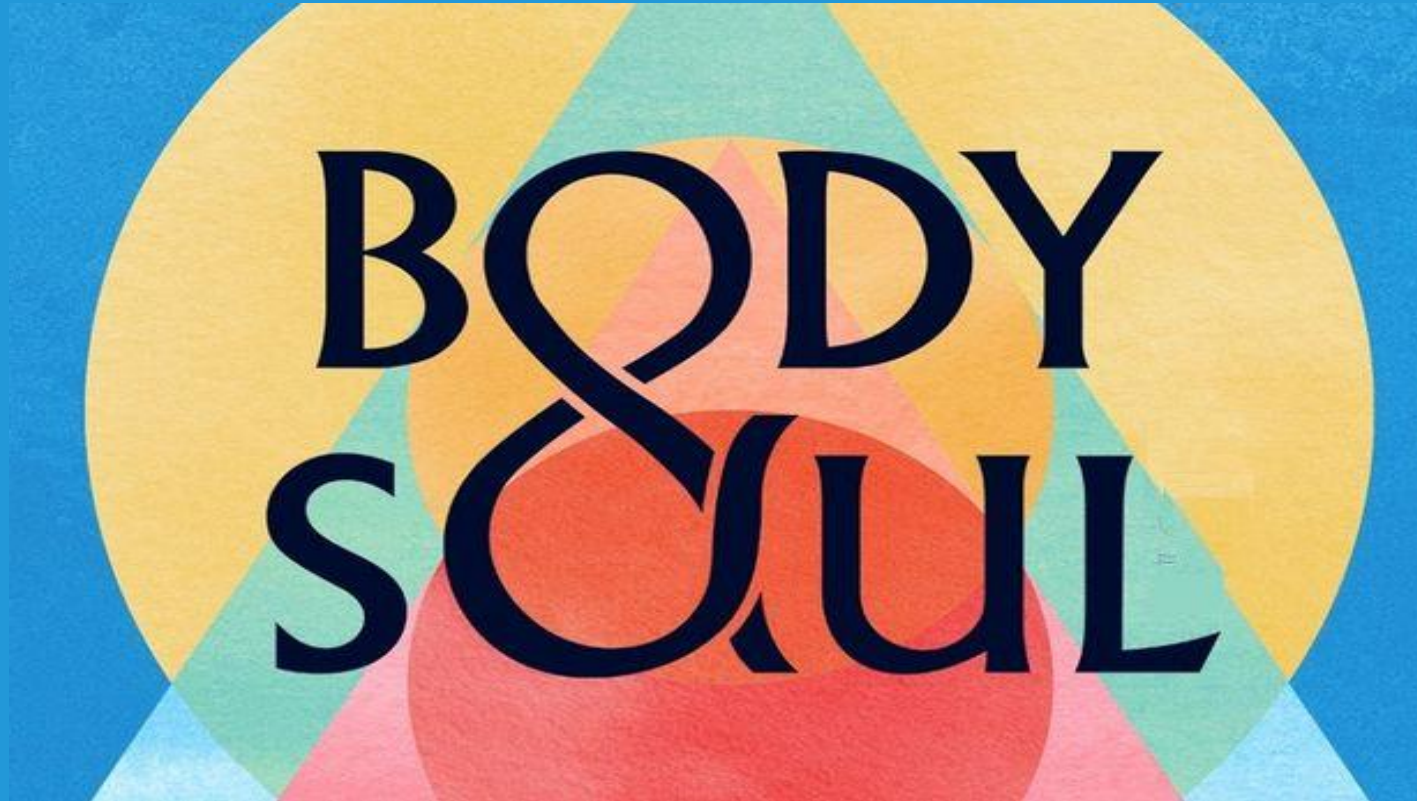

10 Different Jazz Versions
Akram Najjar

Music Talk: 11 October 2021



Wissam Boustany:
Journey of a Sensualist



**Music Talk:
25 October 2021**

**David Marks:
A Short and Selective History of the Clarinet
(Part 1: A Classical Overview)**

EASTERN VOICES WESTERN ECHOES

Music Talk:
1 Nov 2021
Peter Brightman

The Peace and
Prosperity Trust





Jerome Kern



Vernon Duke



Irving Berlin



Johnny Mercer

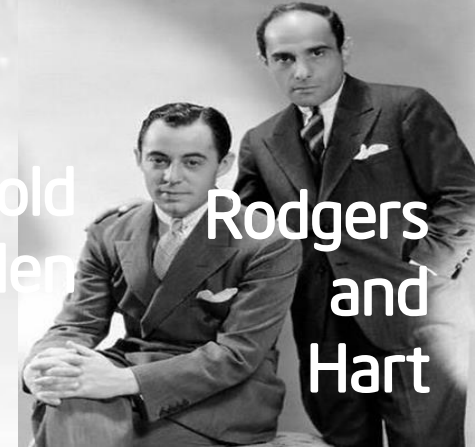

Harold Arlen

Rodgers and Hart

Music Talk:
8 Nov 2021

12 Songwriters, 1 Song Each
Akram Najjar

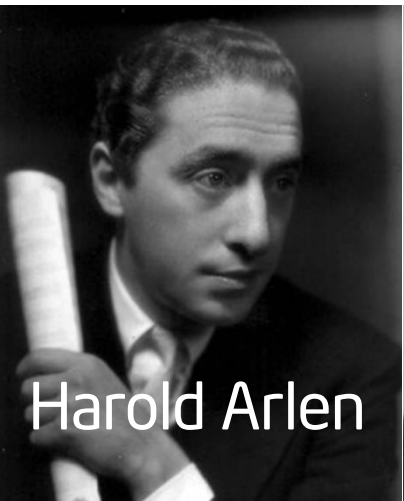

Harold Arlen



Cole Porter

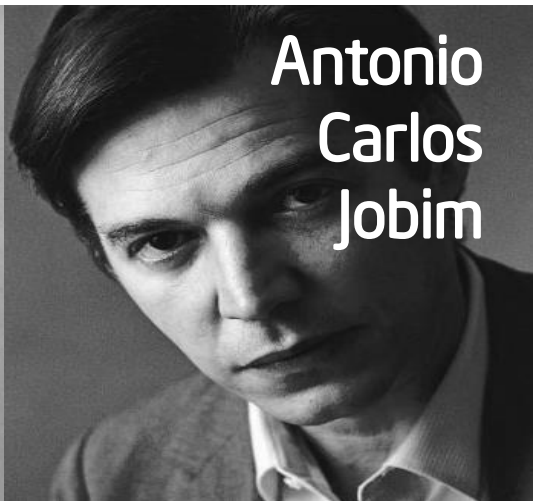

Antonio Carlos Jobim



George and Ira Gershwin

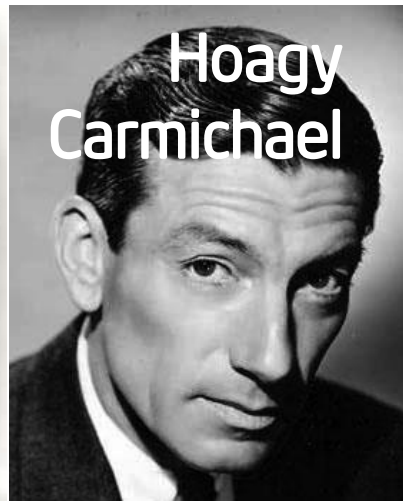

Hoagy Carmichael



Part 2: 12 Songwriters, Different Songs

22 Nov 2021

Akram Najjar

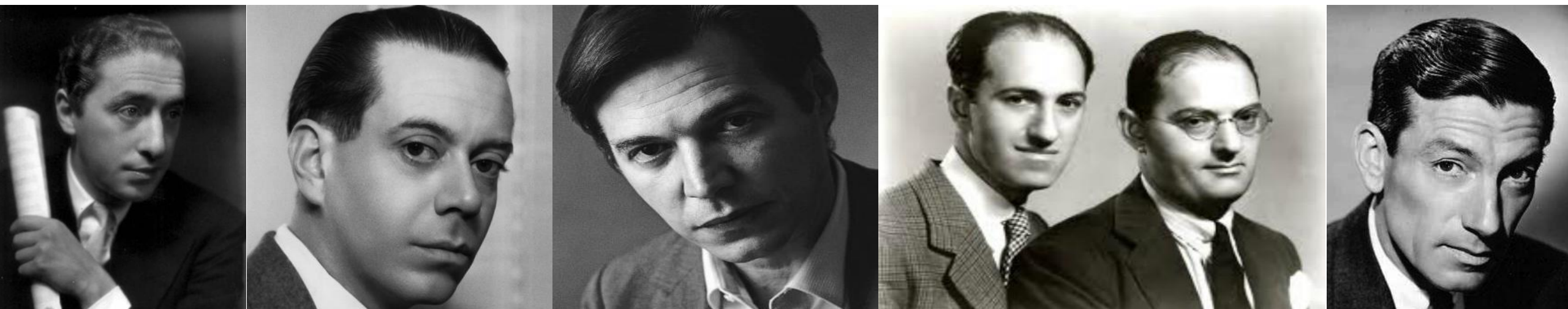

The Nobel Prize
By whom?
For Whom?
How and Why?

Viviane Mardelli
6 December 2021



A woman with dark hair, wearing a white tank top, is leaning on a black grand piano. She has her chin resting on her hands and is looking towards the camera with a slight smile. The piano is open, and the interior is visible. The background is dark.

Pianist Nada
13 December 2021

Music Talk:
Beethoven's 2 Favorite Sonatas

امسية مع فيروز ومسرحياتها
اكرم الريس - (باللغة العربية)

An Evening with Fayrouz and
her Theatrical Productions
Akram Al-Rayess (Arabic)



13 كانون الأول 2021
13 December 2021

17 January 2022

How Not to Get Convinced

Akram Najjar

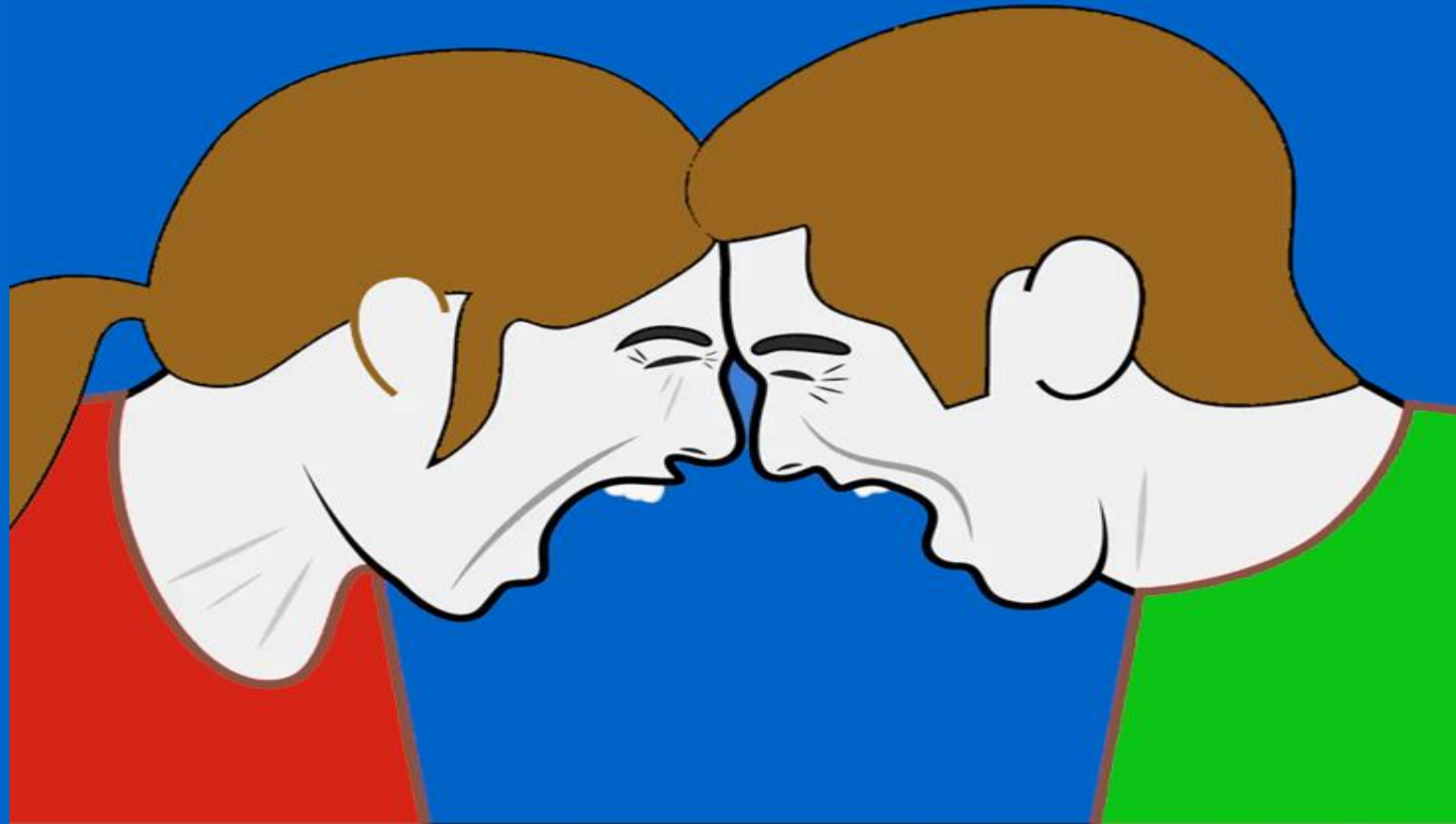

Music Talk:
24 January 2022

Fady Jeanbart:

Presents
"An evening of
wonderful **Baritone**
Arias"



7 February 2022

“The El-Qaa Heritage
Revival Project in
North Beqaa”

Alia Fares,
Salam Kallas and
Jamal Farhat



14 February
2022

The Fascinating Roots of Religion
Emile Nucho

EL COLEGIO DE SINALOA

TRABAJO / ARTES / CIENCIA

21 February
2022



The Moise A. Khairallah Center
for Lebanese Diaspora Studies

Akram Khater

Music Talk:
28 February
2022



Part 2: The Clarinet in Jazz
David Marks

How to Solve Problems by Identifying their “Puzzle Type”

Akram Najjar

7 March 2022

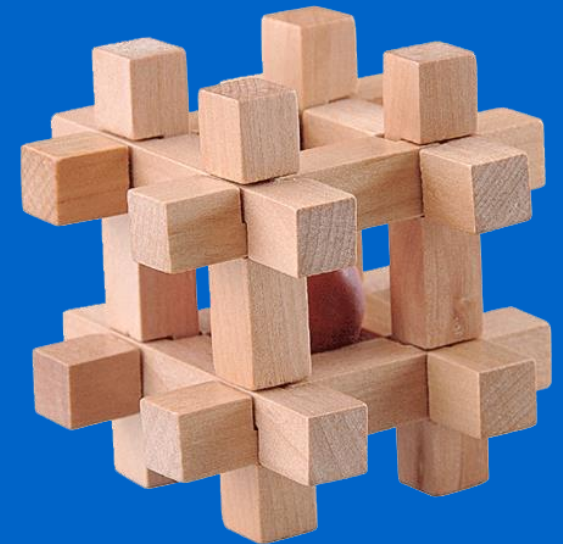

A detailed painting of a 19th-century salon scene. In the center, a woman in a white dress stands holding a book, while another woman in a pink dress sits nearby. To the right, a man in a dark suit sits at a piano, playing. The room is filled with other people in period clothing, some seated and some standing. A large, ornate chandelier hangs from the ceiling, and a fireplace is visible in the background. The overall atmosphere is one of a formal social gathering.

Music Talk
28 March 2022

Was Schubert an Expressionist?
Let us Look into his Last Sonata (D960)
(Akram Najjar)

The Intricacies of the Lebanese Electoral Law

Dr. Makram Ouaiss

19 April 2022 (21:00 Beirut Time)



Pangolins are People Too



Richard Peirce

9 May 2022 (19:00 Beirut Time)

Lebanese Amber: An Exception Window to the Past

Dany Azar

16 May 2022 (19:00 Beirut Time)



The Beatles: 8 Songs + 1 Game



Akram Najjar

23 May 2022 (19:00 Beirut Time)

Brahms' Violin Concerto:

Developing Variations in the First Movement

Akram Najjar

6 June 2022



Birth of an Idea:

How and When did the Idea of a Greater Lebanon Emerge

Charbel Al-Hayek

13 June 2022



Bergman's Persona:

A Battle against Realism

(Akram Najjar - 20 June 2022)



Aromas and Essences of Lebanon: Past, Present and Future

Joumana Boustany

27 June 2022



Why the toss of a coin means you can trust a new cancer treatment.... ?

Dr. David Cameron

4 July 2022 (19:00 Beirut Time)



Mahrajaan:

A New Approach to Film in a Novel in Arabic

Jad el Hage

13 July 2022



Pierre Abi-Saad

25 July 2022



The Lebanese Fish Fossils:
100 Million Years

- 1) Rayane Awkal
- 2) Zuheir Al-Faqih
- 3) Najla Hamadeh
- 4) Rasha Salman
- 5) Akram Najjar

Reviews of Literature on Video

31 October
2022

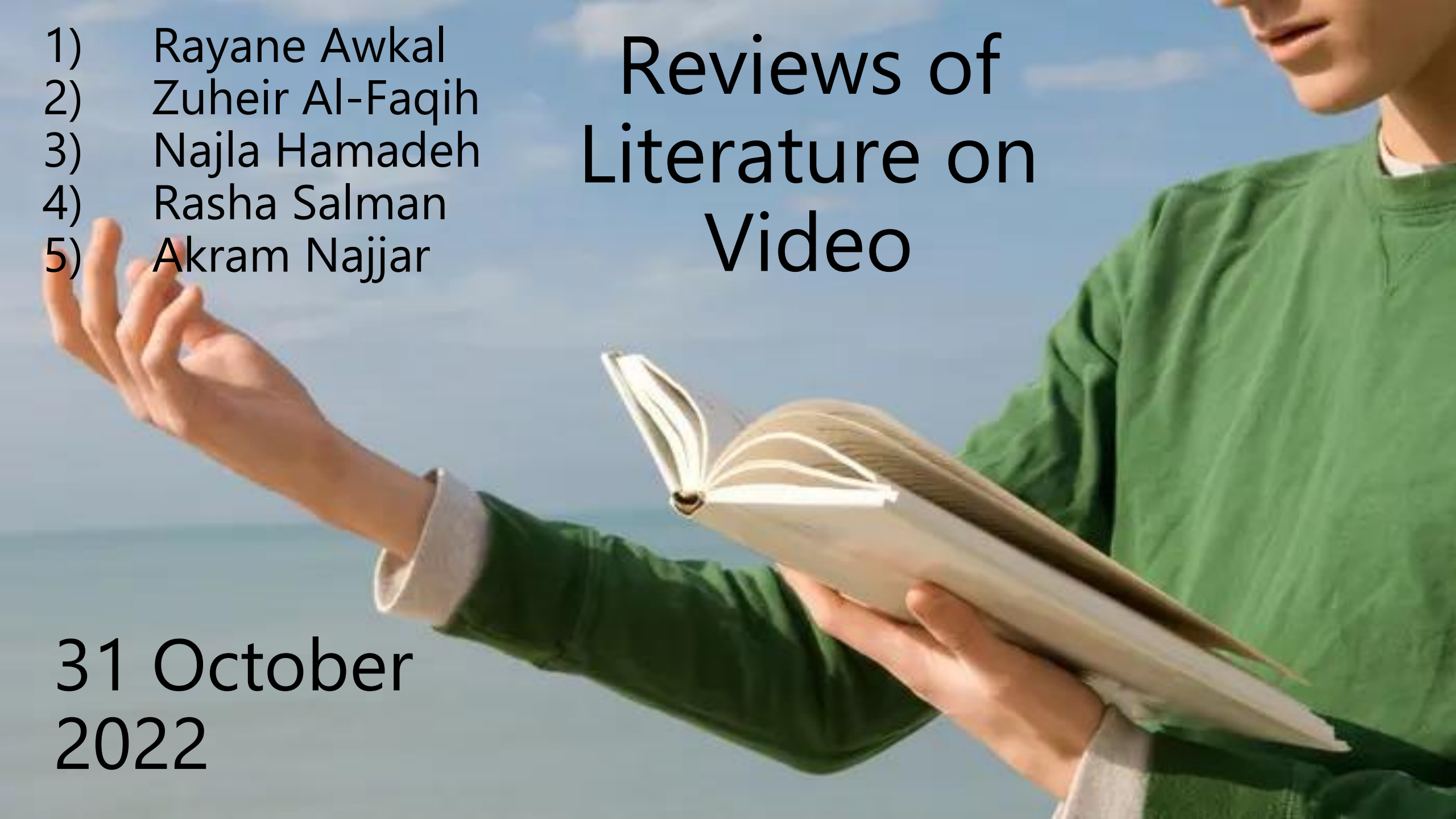

The Dabke, a Lebanese Heritage Treasure

Mo'taz Hassan



7 November 2022



Logical Card Tricks (with no Deception)

Akram Najjar

Monday 21 November 2022

16 January 2023

الحكايا اللي ما بتتحكى

شياطين الدومينو

عن الحرب والرغبة، الآباء
والأمهات والجداات

The Domino's Devils:
Stories that Cannot be Told

منى مرعي





The Finale of the Ninth Symphony

Akram Najjar
9 January 2023

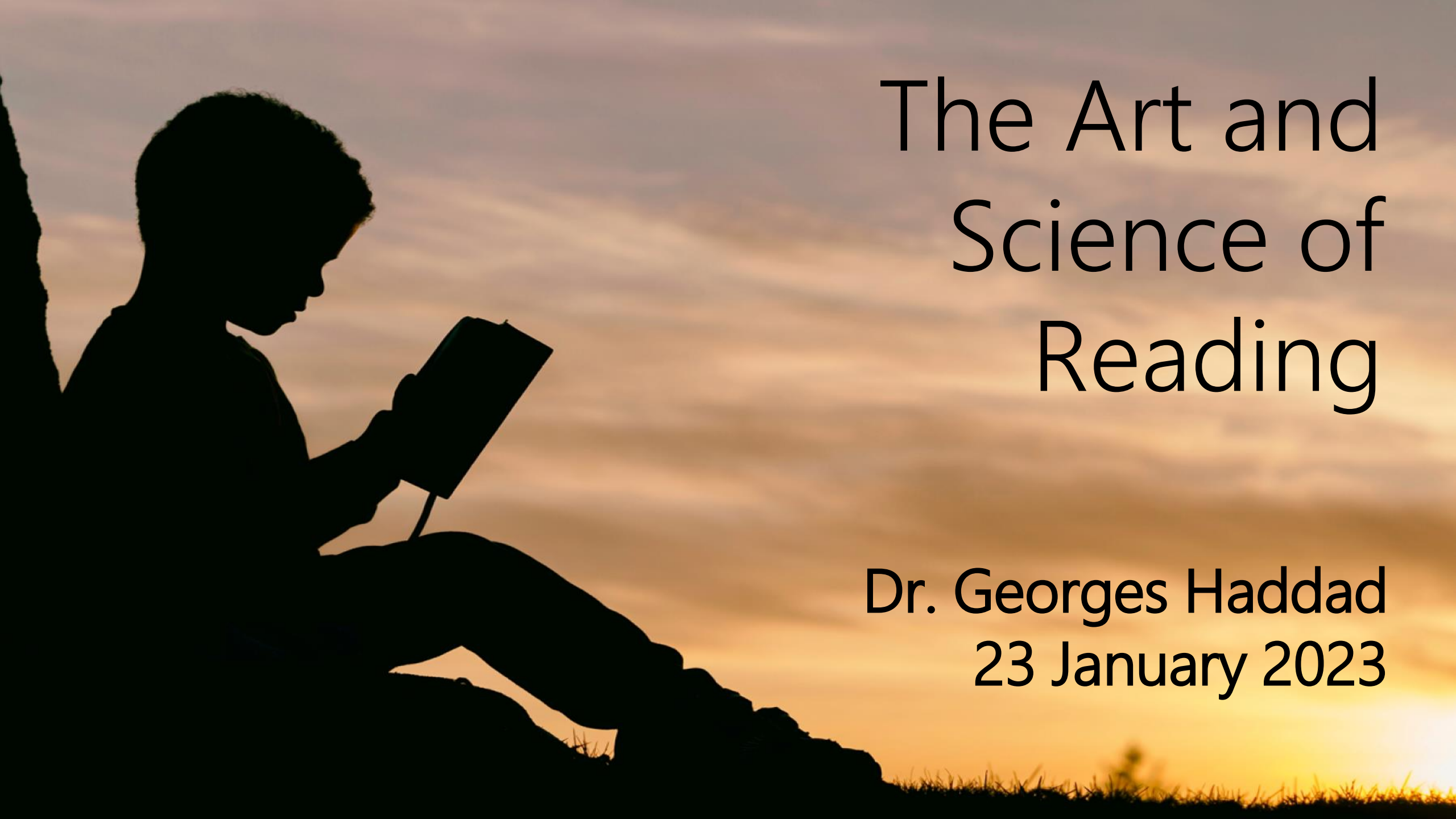

The Art and Science of Reading

Dr. Georges Haddad
23 January 2023

A portrait of Franz Schubert, a man with dark, curly hair and round spectacles, wearing a dark coat and a white cravat. The background is a plain, light-colored wall.

Schubert's
Piano Quintet "The Trout"
(A Major D667 Op 114)

Akram Najjar
Monday 27 Feb 2023

Manal Abdallah
6 March 2023

The Use of Music
and Song for
Language Acquisition



AL-HODA "THE GUIDANCE"

A Daily Arabic Paper

Published every day except Sundays and
Holidays.

Editor and Manager

N. A. MOKARZEL

81 Greenwich St., New York City,
U. S. A.

RATES OF SUBSCRIPTION PER ANNUM
\$3 IN THE UNITED STATES AND COLONIES,
CANADA & MEXICO.
\$6 FORTY IN FOREIGN COUNTRIES

Cable Address:

"Mokarzel" NEW YORK.

إِلْهُدَى

جريدة يومية ثقافية تهادية اخبارية

تجهز الاشتراك عن مائة كلمة
• دولارات في ولايات أمريكا المتحدة وخطاتها
وكندا والكيبيك
• ٣٠ دولار في سائر المهن
جميع المراسلات المتعلقة بالبريدية ينبغي ان تكون باسم مديرها
يوم مكرزل
الى عدد ٨١ شارع كريولوش - نيويورك
الحيثان الثقافي • مكرزل • نيويورك

Entered as Second class matter at
The N. Y. Post office

ايروز الاعلانات ٤ دولارات في السنة من سطر في الصفحتين الاولى والثانية و٣ في الثالثة و٢٠ في الرابعة

كل رسالة شخصية مأجورة وايروز العدد منها ١٥ دولارا عن مرة واحدة - وايروز سطر الاستعلامات نصف دولار للمرة الاولى وربع دولار لكل مرة بعد ذلك والبرع محمل

New York, Saturday, JANUARY. 3, 1903.

نيويورك السبت في ٣ كانون ٢ سنة ١٩٠٣

The Arabic Language Press in
America and its Impact

Dr. Edmund Gharib
13 March 2023



Y-a-t-il un courant de musique classique libanaise?

Zeina
Saleh
Kayali

27 March 2023



CineClub
"The Spirit of
the Beehive"

Victor Erice (1973)
(English Subtitles)

3 April 2023
(Abajour Restaurant)

Events from Tonight
till **End of May**

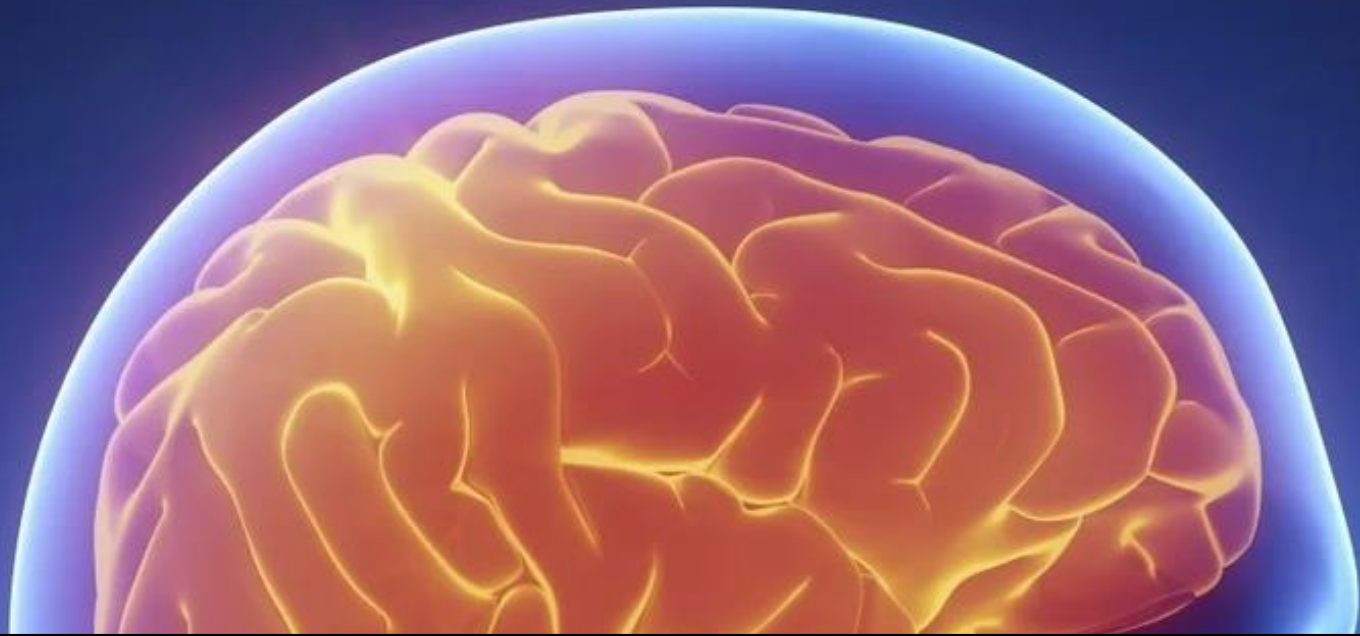

“The Ultimate
Think Tank”

Tonight

8 May 2023



The Healing Music of the Shaman Icaros

(Rani Bitar)

15 May 2023



Smile and Say Cheese (Kamel Lawand)

22 May 2023

The Legacy and Music of Zaki Nassif (Akram el Rayess)



29 May 2023

Early Signs of Major Medical Conditions



Dr. Nabil Kanaan
5 June 2023



OR



Risky Health
Behavior:
(The relationship
between lifestyle and
disease prevention)

Dr. Nabil Kanaan
12 June 2023



Akram Najjar
26 June 2023

30 After Dinner
Bets You Can
Always Win



Lions, Bones and Bullets

Richard Peirce

14 August 2023

A person wearing a green sweater is shown from the chest up, holding an open book in their left hand. Their right hand is raised and gesturing, with fingers slightly curled. The background is a clear blue sky with some light clouds. The text "Read Aloud 7" and "Recite your Own Works" is overlaid on the top left of the image.

Read Aloud 7

Recite your Own Works

4 September 2023



سهيل منيمنة - 11 أيلول 2023

الأهمية الاقتصادية والاجتماعية لأسواق بيروت القديمة



Drama and Beyond:

A Journey through Arabic Theatre's Past

Aliya Khalidi

18 September 2023

WE LOVE SHORT FILMS

25 September 2023



Suzanne
Maraea
16 Oct 2023

How to Write Impacting Stories about your Life



Monday Talk
30 Oct 2023

To Sleep Per Chance to Dream: Sleep Apnea
Myths, Facts and Anecdotes about Sleep
Hrayr Attarian, MD and Alain Sabri, MD

Brahms: the Relationship between his Life and his Works



© imago images / Photo12.com

Music Talk
Akram Najjar
Mon 6 Nov 2023





شعر التفعيلة والشعر المترجم:
مقاربة نقدية موسيقية بين خليل حاوي
وت. س. إيليوت

Arabic Poems:
Between Translation and Music
(Extracts from Khalil Hawi and T. S. Eliot)

Literary Talk:

Manal Abdallah / Dorine Saad / Maria Nasr

Mon 27 Nov 2023

Four Hidden Songs that Need Exposure



Music Talk:
Akram Najjar
Mon 4 December 2023



The Unending Crises:

The Kurds and their Neighbors

Monday Talk:

Dr. Edmund Ghareeb

Mon 18 December 2023

Monday Talk:
Dr. Edmund Ghareeb
Mon 8 January 2024

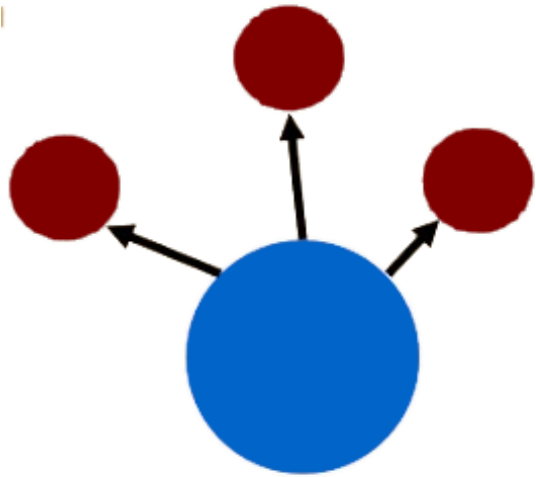

At the Crossroads:
The Decline of the **Unipolar**
World and the Rise of a
Multipolar One

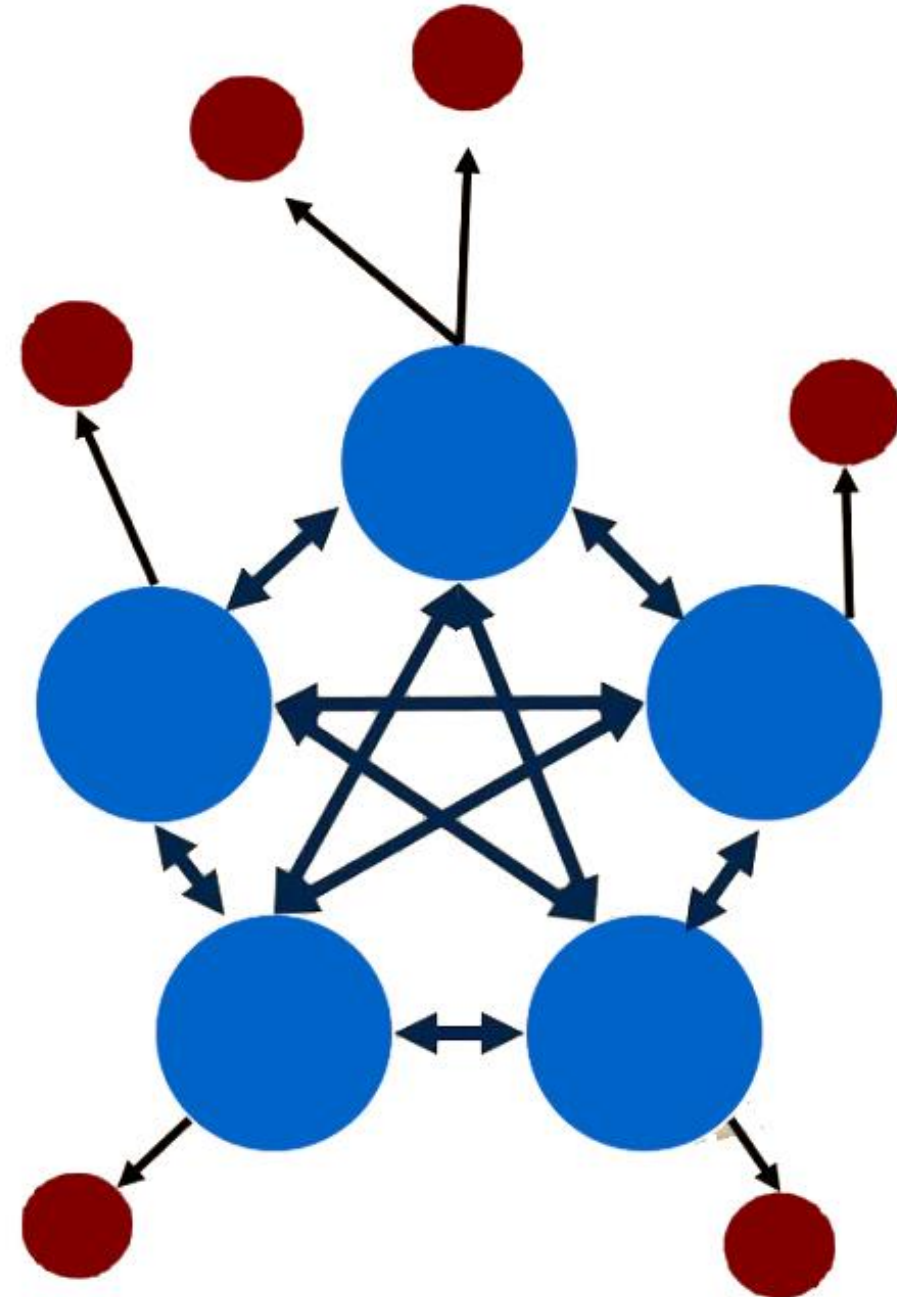

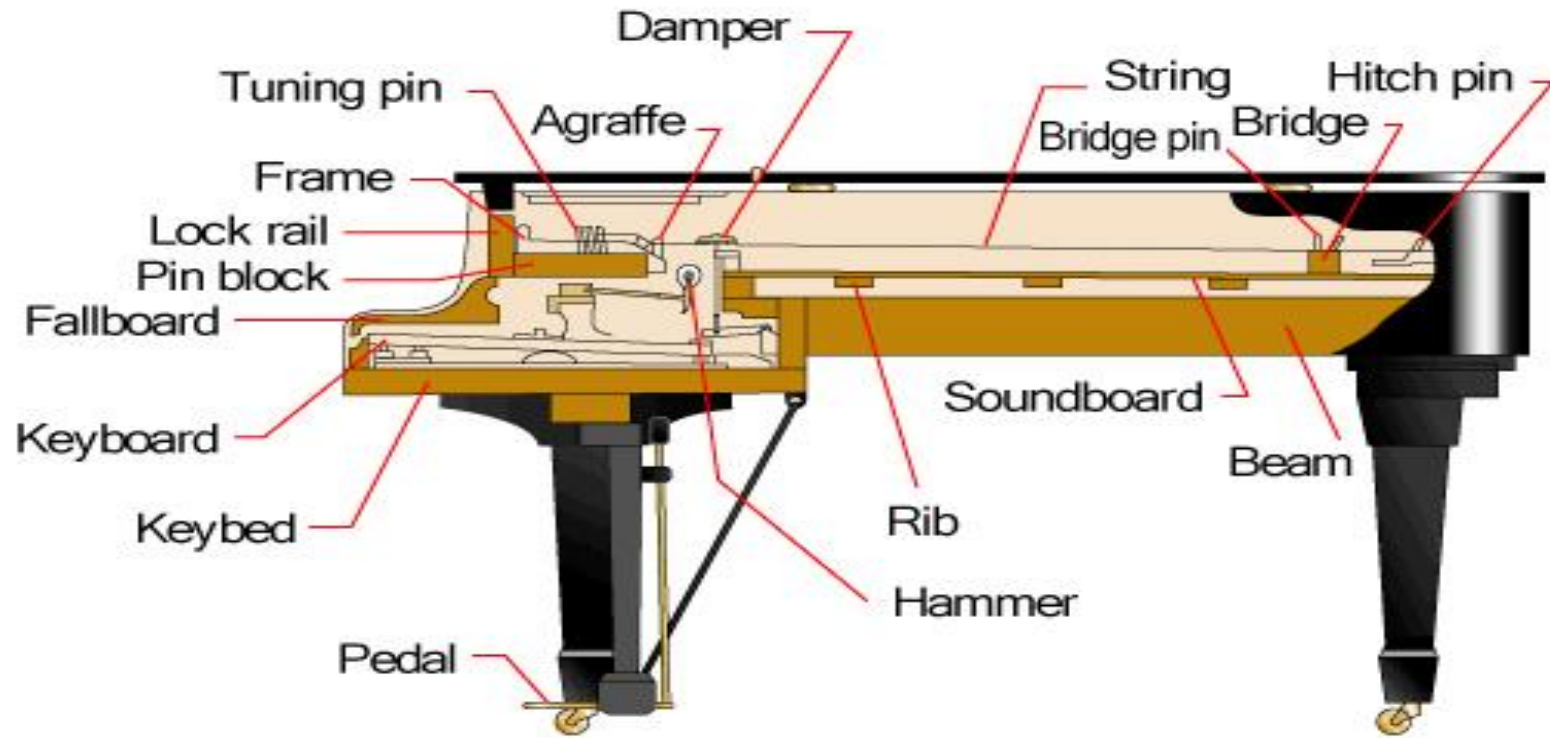

Relating the Evolution of the Piano and the Music written for It

العلاقة بين تطور البيانو والموسيقى المكتوبة له

Ziad Kreidy

Mon 22 January 2024

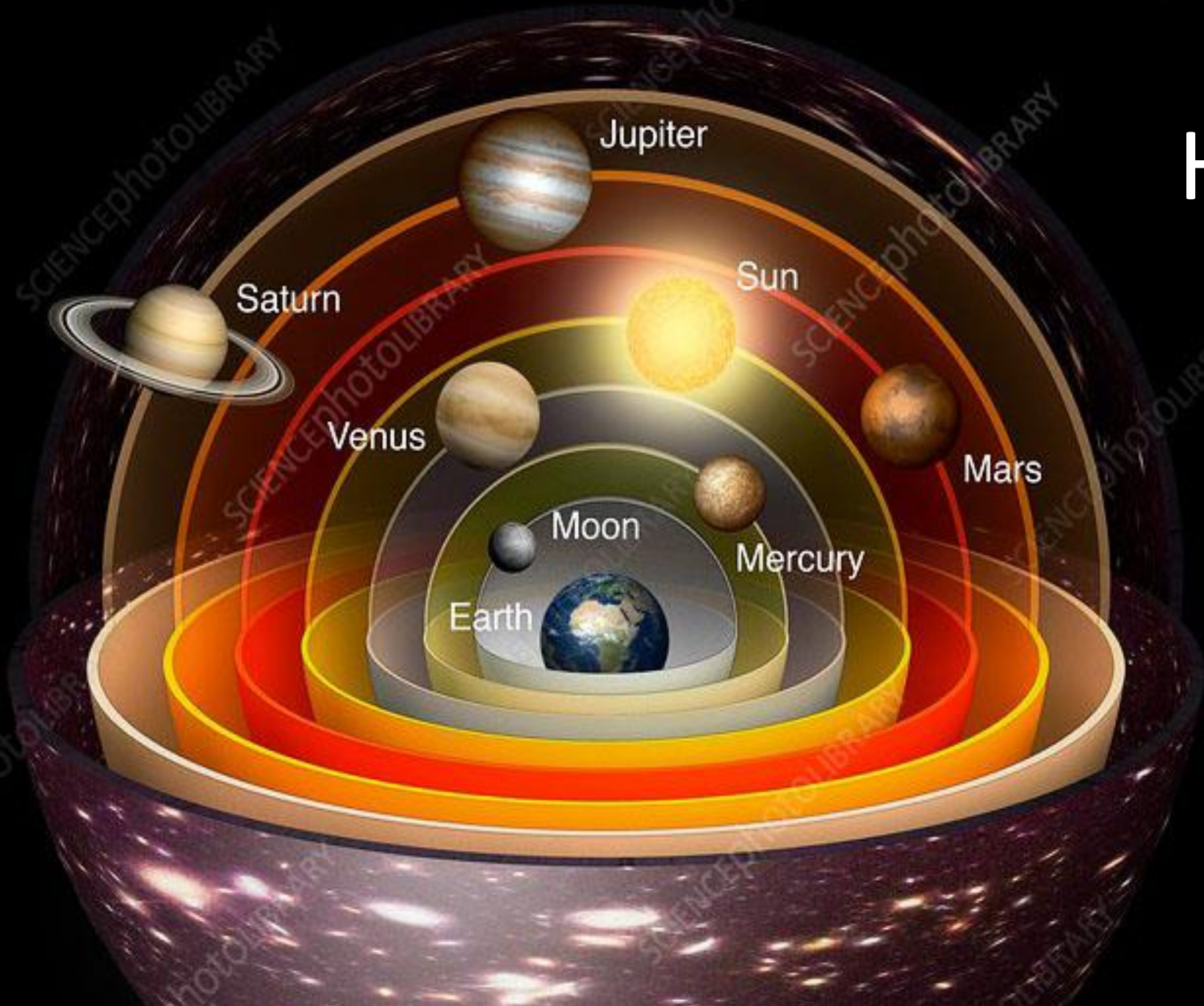

How Nature Repeatedly Humbled Humanity

Akram Najjar
29 January 2024

“Universal Basic Income” and a Possible Solution for Lebanon

Thomas Schellen
5 Feb 2024

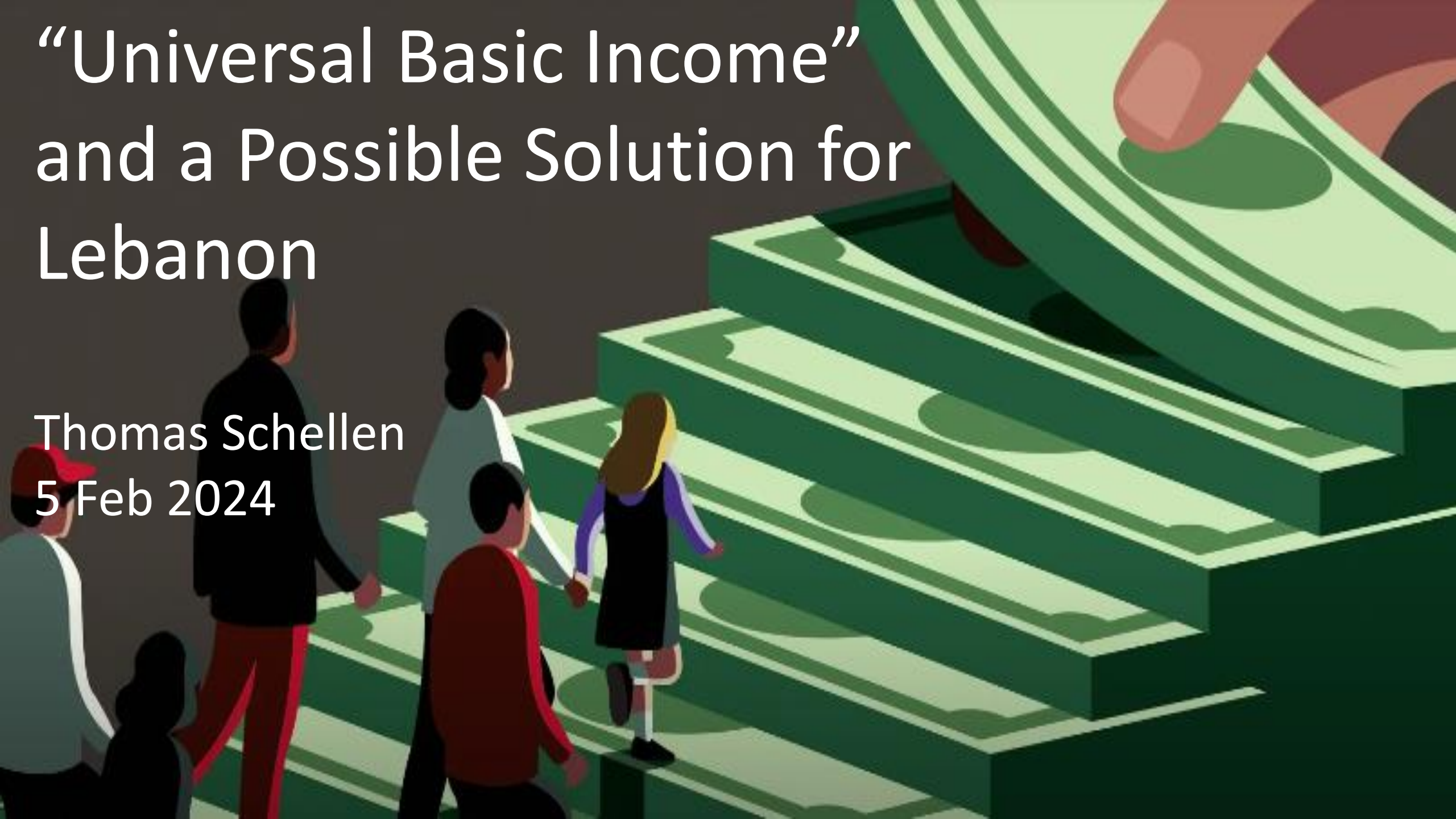

This is Part 2 of
Last Week's Talk

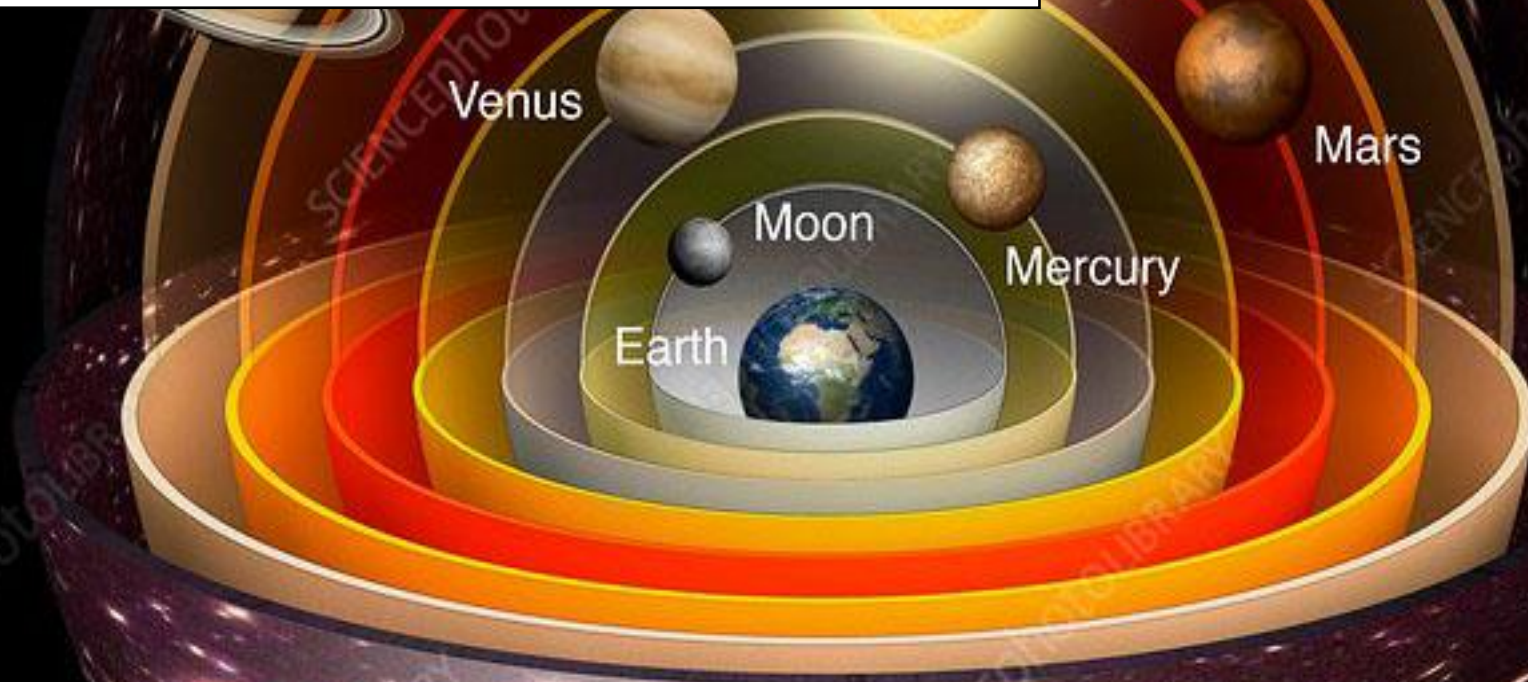

How Nature Humbled Humanity

Akram Najjar
12 February 2024



The Making of the Oud A Personal Journey

فن وتقنية صناعة العود
رحلة شخصية

Salim Jouni
19 Feb 2024

The Impact of the 7 Human Systems on our Lifestyle and Wellbeing

Jad Naissi

11 March 2024

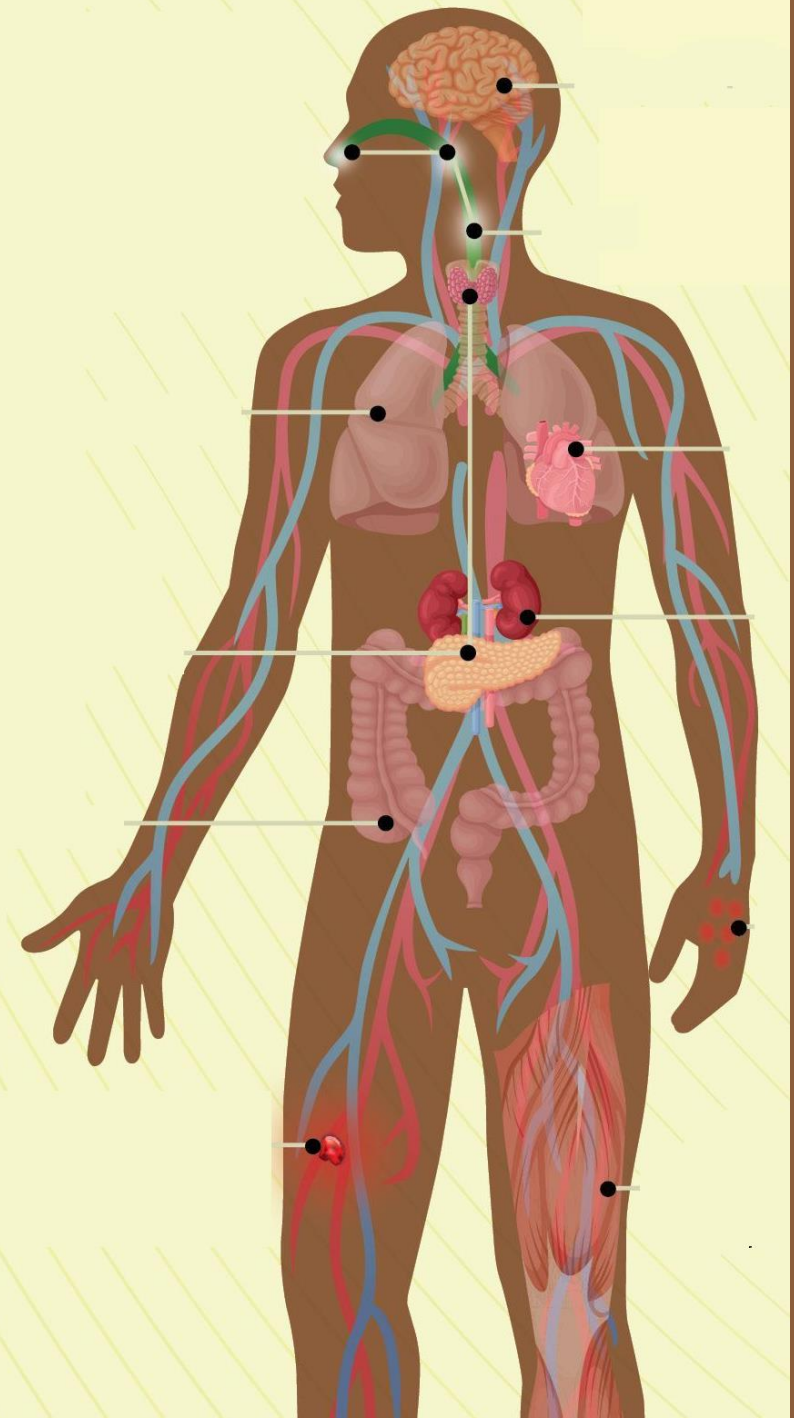

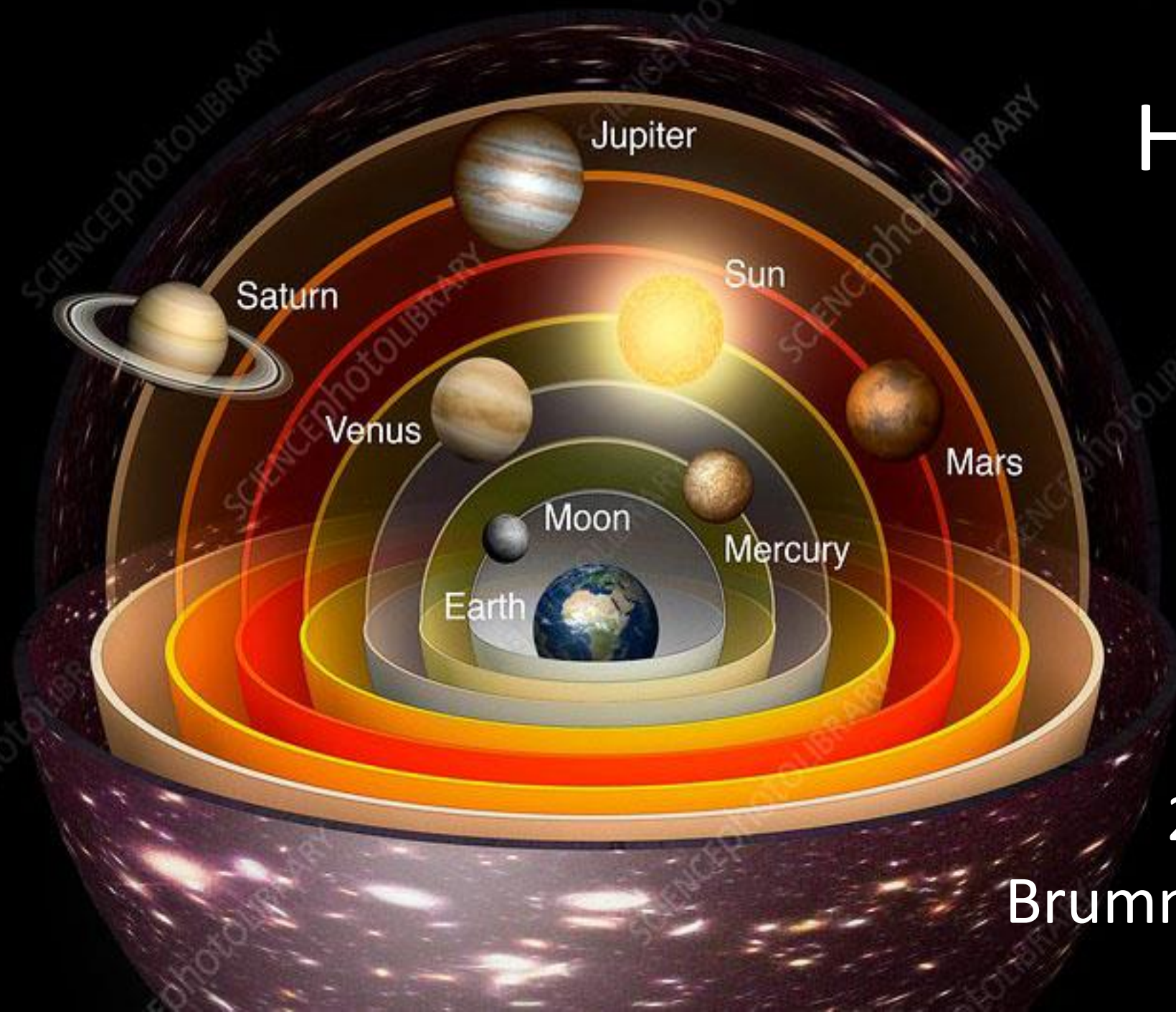

How Nature Repeatedly Humbled Humanity

Akram Najjar
21 and 27 March
Brummana Highschool

Social Awareness

Debates

Art Talks

Literary
Talks

Workshops

Discussions

Monday Talks

Read

Aloud

Read
Aloud

Cinema
Talks

Heritage Trips

Art Films

Music
Talks